

EXTRA SERVICES

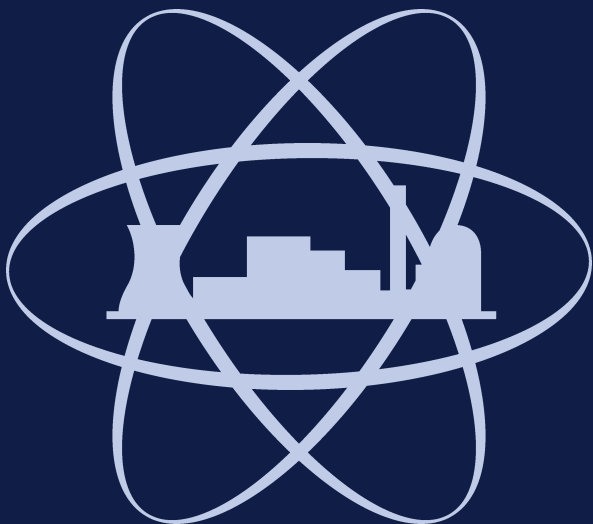

SERVICE

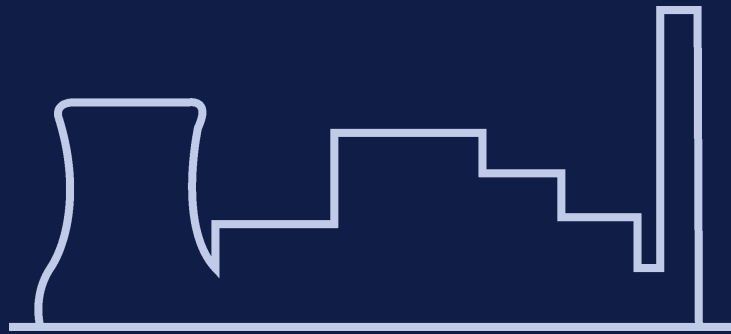
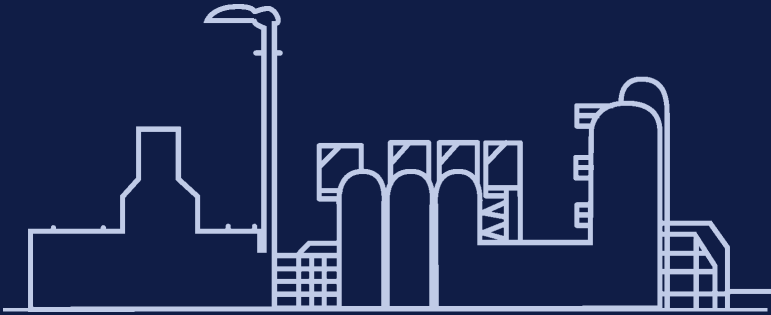
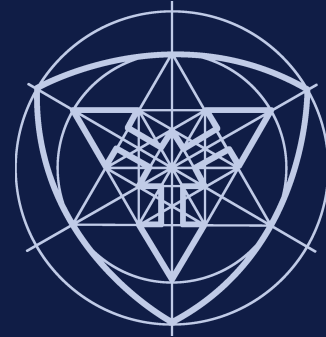
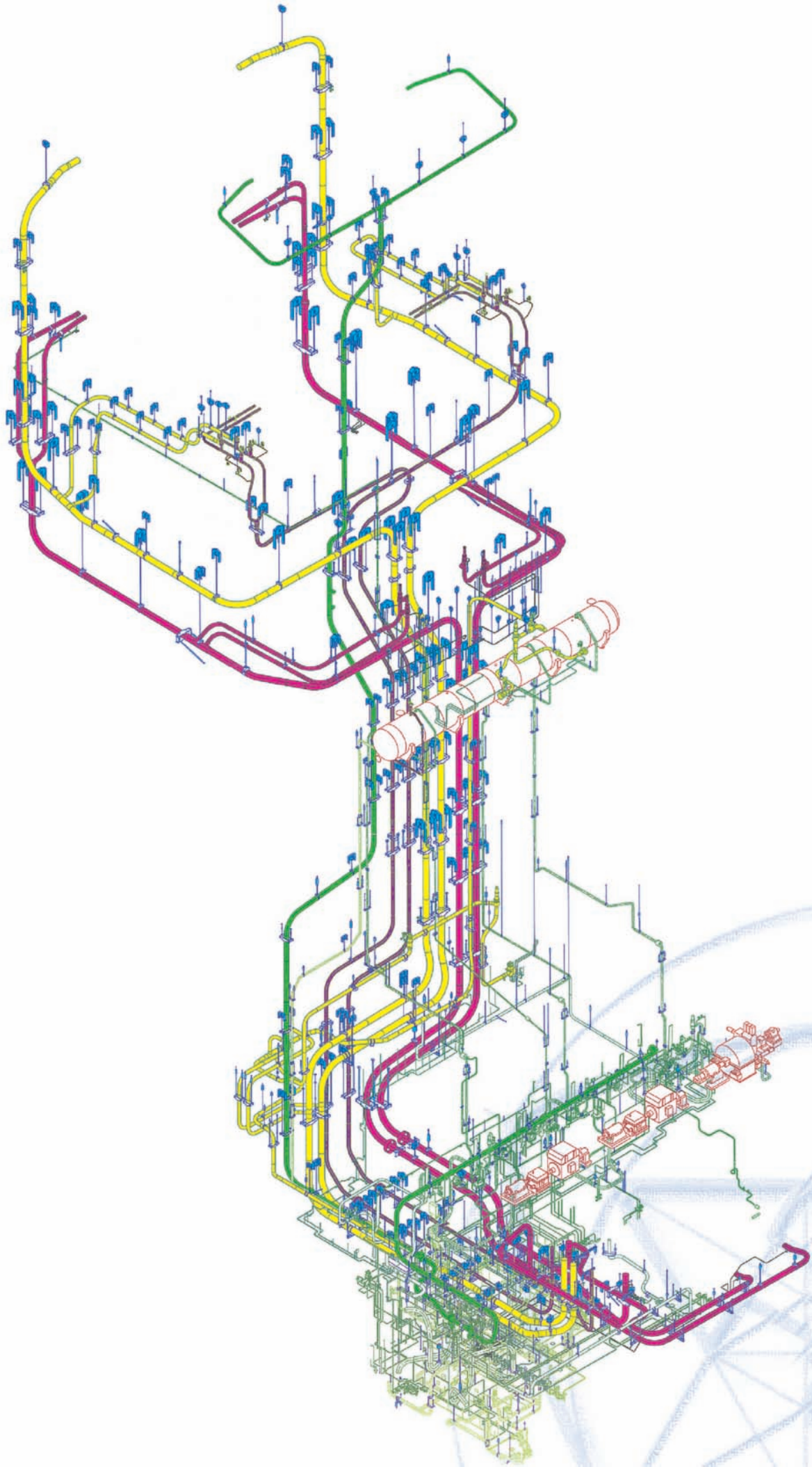

CONTENTS

PAGE

Supplementary services _____	9.1
Engineering _____	9.5
Field service _____	9.11

0

1

2

3

4

5

6

7

8

PRODUCT
GROUP **9**

SUPPLEMENTARY SERVICES

PRODUCT GROUP 9

The LISEGA product program introduced in the **STANDARD SUPPORTS 2010 catalog** corresponds to current technological developments in appropriate supports for piping systems in industrial plant construction.

The relevant international requirements are satisfied at the highest level.

Special fields of application

The standard designs described cover the usual range of application. For special areas, e.g. nuclear plants or offshore operations, extended measures in the question of material quality or corrosion protection are required occasionally. The fulfilment of special customer requirements is guaranteed by the integrated quality assurance system. The applicable certification is supplied with the order.

Service areas

Increasing pressure from costs through international competition has led to the dispersal of service areas (outsourcing). Following the growing demand, LISEGA has readjusted its capacity in the fields of engineering and onsite service at all locations. For support design, the use of specially developed computer software enables particularly effective support, e.g. in the 3D sector.

Standardized supplementary services

By way of specific supplementary services the LISEGA standard program can be adjusted to particular needs. The field of product application is widened in this way and the LISEGA performance package further optimised. All the significant supplementary services are standardized according to the LISEGA modular system and cataloged in Product Group 9.

9.0 Supplementary services

9.1 Adjustment work

Constant and spring hangers are set and blocked for cold load by electronic force and travel measurement on a hydraulic test bench.

9.1.1 Storage of blocking devices

If required, spring hangers can be supplied with storage points for blocking devices on the housing (after deblocking). This is standard on the constant hangers.



9.2 Quality management

9.2.1 Inspection reports

When required, inspection reports with digitally recorded values can be supplied as functional certification for constant and spring hangers and shock absorbers.

9.2.2 In service testing

In service testing for the mechanically functioning components of all makes can be carried out in the relevant LISEGA plants or on mobile test benches in the installation itself.

9.2.3 Material certification

The following material certificates can be supplied on request:

9.2.4 Supplier COC

Manufacture and dispatch as per order can be confirmed with a Certificate of Compliance.

9.2.5 Material certificates 2.2

The material in all catalog components can be certified by material certificates according to EN 10204 - 2.2 (not in US).



Compilation of component documentation. ►

9.2.6 Material certificates 3.1 B for special components

Components affected by the direct flux of force, e.g. the springs of constant and spring hangers, can be supplied with material certificates acc. to EN 10204 - 3.1 B (not in US).

9.2.7 Complete traceability through CMTR

The complete traceability of material for all catalog product components by way of separate manufacture is possible acc. to Certified Material Test Report.

9.2.8 Pre-examination documents

The standardized products have largely been qualified through independent authorities (TÜV or VGB) by specified type and suitability tests.

For special, particularly non-standardized designs, pre-examination documents such as design drawings, parts lists, calculations, test sequence schedules and welding plans can be supplied.

9.2.9 Stricter quality requirements

For fields of application with stricter security and quality requirements, such as nuclear installations, the quality assurance program is applied at the highest quality level. All the stages of order processing and handling follow recognized procedures corresponding to the quality requirements of standard codes and guidelines such as KTA or TÜV suitability tests, as well as ASME Sect. III, NCA and NF.

The following aspects are particularly considered:

- materials acquisition from approved suppliers
- complete traceability of material
- special supervision of manufacture

All sectors are fully documented.

9.3 Surface treatment

In addition to specified, standardized surface treatment, extended corrosion protection according to **Technical Specification**, Section 8, page 0.10, can be supplied.



9.3.1 Spring hangers and spring supports up to load group 9

▲ Immersion painting

In addition to galvanizing, all exterior surfaces of components are treated with a barrier coating, layer thickness 30µm, and a dual-component acrylic-polyurethane blue topcoat, layer thickness 60µm. Total layer thickness: > 100µm

9.3.2 Constant hangers and supports, variable spring hangers from load size 9, rigid struts and trapezes.

In addition to the standard coating, all outer surfaces of components are treated with a dual-component acrylic-polyurethane blue topcoat, coating thickness 60µm. Total layer thickness: > 180µm

9.3.3 Connecting elements

The connecting elements in Product Group 6 can be supplied hot dip galvanized from stock.



Spray painting



Load chain assembly

9.3.4 Pipe bearings and pipe clamps

Pipe-surrounding components can be treated with a special coating on a blasted surface.

9.3.5 Special treatment

Besides the above-mentioned processes, other kinds of corrosion protection can be agreed upon for all products. Due to storage-related availability of standard designs, separate manufacture may be required in this respect. This applies particularly to hot dip galvanizing.

9.4 Preassembly

If not otherwise agreed, the components making up a shipment are packaged in bundles according to type.

For easier handling and economical assembly on site, individual components can however be supplied pre-assembled in load chains, bundled and marked.

9.4.1 Preassembly of load chains

The load chains are pre-assembled according to support drawings and marked with the support position number. Constant and variable spring hangers, as well as larger pipe clamps (bulky components), are kept separate for easier handling and marked accordingly.

9.4.2 Preassembly of pipe clamps and pipe bearings

Pipe clamp and pipe bearing halves are bolted together and supplied as complete units.

9.5. Designation and marking

If not otherwise agreed, the components are sorted and packaged according to type and marked for quantity, type number and order number. Additional designations and markings can be supplied if required.

9.5.1 Designation of individual parts

If required, all components can be individually marked as to type, support or order number.

9.5.2 Second name plate

Variable spring hangers and constant hangers can be fitted with a second name plate if required.

9.5.3 Second load and travel scale

Constant and variable spring hangers can be fitted with a second travel scale and constant hangers with a second load scale if required.

9.6 Packaging

For the various packaging requirements appropriate types of packaging are available:



Load chains, preassembled, bundled and marked

9.6.1 Inland packaging

Sturdy wooden crates or pallets fitted with skids for fork-lifting are supplied for road or rail transport.

9.6.2 Seaworthy packaging

Special wooden crates are used with skids for fork-lifting and reinforced side walls for crane operations. The inside of the crate lid is covered with plastic sheeting to prevent moisture ingression.

9.6.3 Further special types of packaging can be agreed upon in detail.

9.7. Transport

If required, we can take responsibility for the logistics of shipment of goods to the site or other destinations (FCA, FOB, etc.)



Part of dispatch section

Seaworthy packaging



Project-related order logistics

ENGINEERING, SUPPORT DESIGN

The proper functional integration of pipe supports into the existing piping and plant concept has a decisive influence on the long-term behavior of pipe systems. The same care and attention should therefore be paid to support planning as to the pipe systems themselves. In this respect, the choice of product and the availability of up-to-date design software has a major effect on the quality of planning.

9.8 Engineering, support design

Besides high quality requirements, it is essential in the planning of supports to keep to tight schedules and economic targets. At the same time, plant operators keep a consciously tight rein on the resources required. To avoid thereby endangering the budgeting and logistics of entire projects, the planning arrangements are placed in the hands of suitable engineering firms (outsourcing).

LISEGA has been a specialist for a long period in the provision of the relevant facilities for the execution of complex planning activities. Highly qualified and experienced technicians and engineers are available at all LISEGA locations. For the optimum fulfilment of all customer requirements, the different areas are equipped with the latest, most

systematically considered. For the design and dimensioning of both supports and secondary steel, the relevant pipe system calculation data as well as detailed plans of the piping layout and structural factors are taken into account.

For the effective transfer of the support arrangements into 2D or 3D models, and to guarantee the economical preparation of drawings, the most sophisticated software is applied. In addition to our own specially developed material the following standard programs are currently in use:

- LICAD
- AutoCAD (2D-CAD)
- MicroStation (2D and 3D-CAD)
- PDMS (3D-CAD)
- Staad III (static / dynamic calculation of secondary steel)
- PSA 5 (pipe system calculation program)
- CAE-pipe (pipe system calculation program)



Engineering in Zeven, Germany

sophisticated software. In internationally overlapping projects, and whenever required, the engineering sections at the various locations work in close association.

Pipe supports for complete plant systems including secondary steel are conceived, planned and drawn up according to project requirements. On the basis of the LISEGA modular system and decades of experience, ready-to-install load chains from structural attachment right through to pipe-surrounding component are generated from standard supports. The relevant international technical codes and standards as well as particular customer requirements are thereby



Engineering in Newport, TN, USA



Analysis of complex support arrangements

The following engineering services are available according to requirements:

9.8.1 Design of support arrangements (load chain designs) with LICAD:

The following data should ideally be supplied by the customer:

- pipe diameter
- loads
- movements
- temperatures
- insulation thickness, if necessary
- piping material
- installation length and position, or corresponding piping and structural plans
- specifications

On the basis of these data, ready-to-install load chains are generated with the LISEGA design program LICAD from standard supports, from structural attachment right through to pipe-surrounding component. The designs so prepared are stored and printed out as scale drawings, including parts lists with load and material data. As an option, location plans and pricing details can be included with the LICAD drawings.

9.8.2 Generation of 2D CAD drawings without supplementary steel

For the preparation of 2D CAD drawings the following information on the drawing layout, in addition to the details in 9.8.1, is required:

- drawing sheet in format DXF, DWG or DGN
- drawing numbers
- location plans

As the basis for the CAD drawing, a LICAD support configuration together with dimensioning, parts list and relevant adjustment data is supplied via a special interface. The drawing sheet required is inserted in the customer's

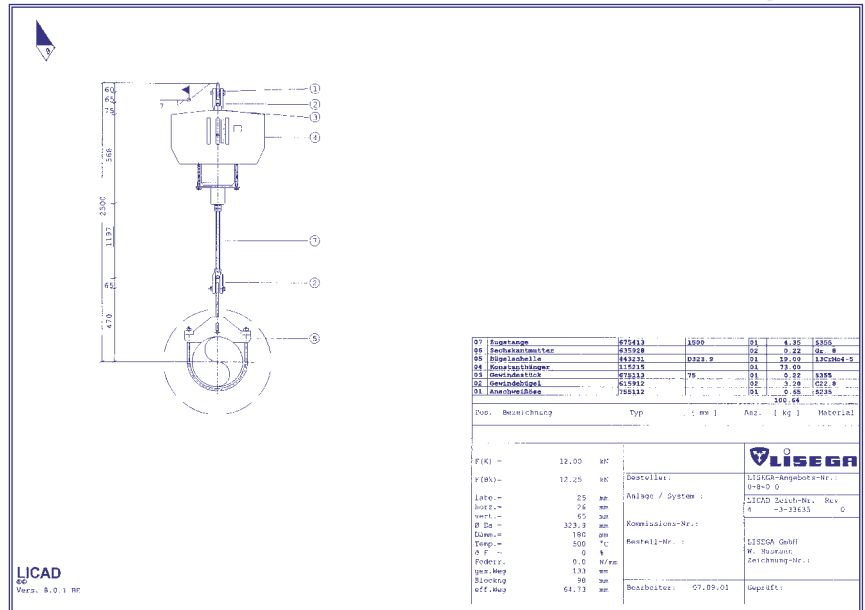

LICAD drawing

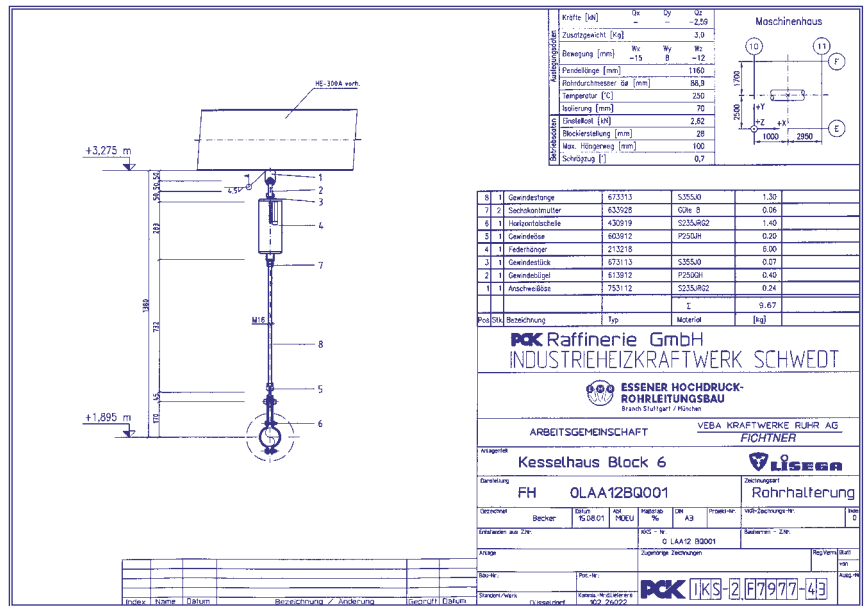

CAD drawing according to customer requirements

specific drawing layout. The CAD drawing is supplemented by a location plan and drawing number.

9.8.6 Support design of 3D models in PDMS

For the design of 3D pipe system supports in the PDMS program, the customer makes a PDMS model complete with pipe systems, steel and all structural components available. In addition, the data listed in 9.8.1 is required for the design of pipe supports. The support points, including the necessary secondary steel, are planned and laid out directly in the PDMS 3D model by experienced designers. LICAD provides the well-tryed basis for this. The load chains generated in LICAD, transposed into 3D data, are integrated into the model with the aid of a PDMS interface. Any secondary steel required can be directly supplemented in PDMS.

Finally, an examination of possible obstructions (interference check) is carried out in the 3D model. The customer receives a complete, fully checked 3D model with all planned support positions and the relevant 2D draw-

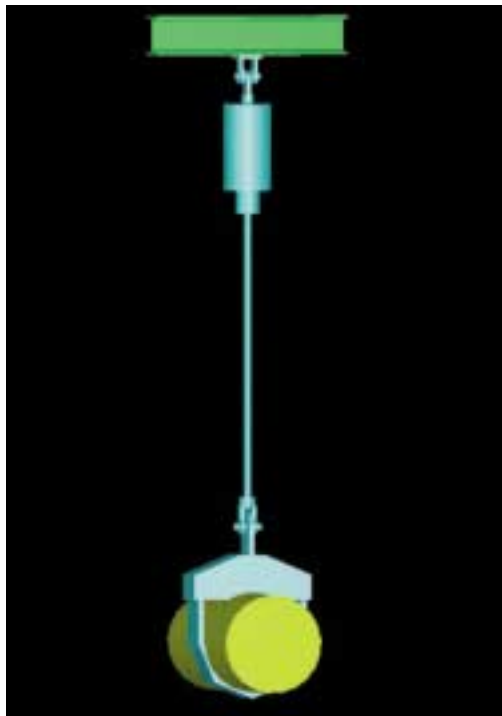

3D PDS display

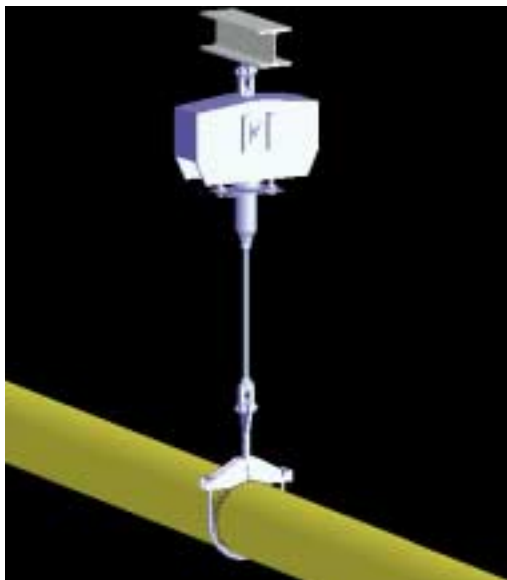

3D PDMS display



2D support drawing generated directly from PDMS 3D model

ings, including parts lists. The support drawings can also be generated in the 3D mode if required.

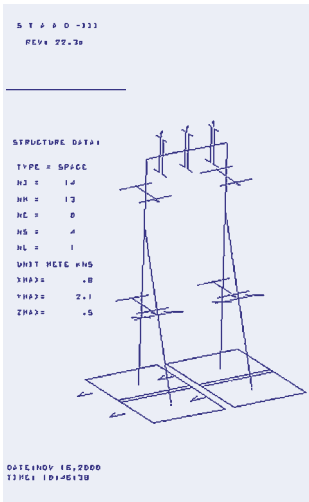

9.8.7 Static calculation of secondary steel including structural attachment loads.

LISEGA provides the design report summary for the dimensioning of the planned secondary steel according to Code AISC or DIN18800.

SUPPORT REACTIONS IN KNS METER

KNT.	LOADCASE	X FORCE	Y FORCE
1	1	.15	5.85
5	1	.09	.59
11	1	-.15	5.85
15	1	-.09	.59

STATIC SYS. = SPACE

Z FORCE	X MOM.	Y MOM.	Z MOM.
.06	.08	.00	-.11
-.06	.05	-.04	-.12
.06	.08	.00	.11
-.06	.05	.04	.12

Design of steelwork with STAAD III

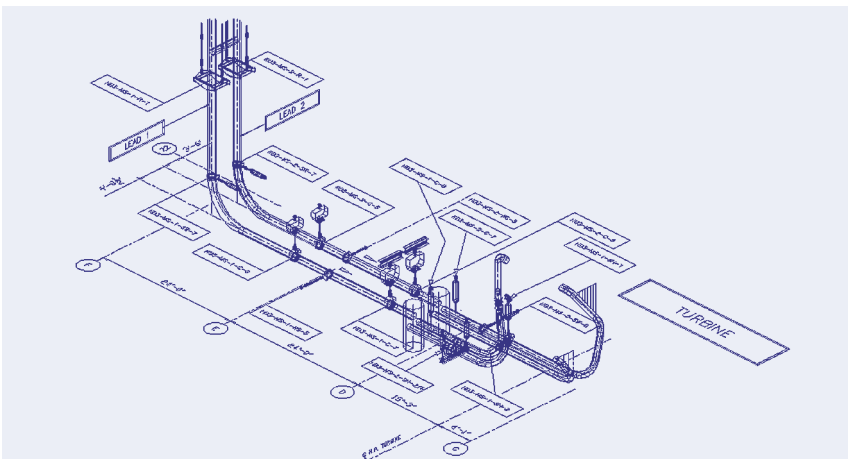

This summary is supplied with the STAAD III statics program.

9.8.8 Pipe system calculation

In older installations it is often necessary for reasons of operational safety to renew pipe systems and supports in order to meet current standards in technology. There is often insufficient documentation available offering information on calculations regarding the original design. If so desired, a static calculation of pipe systems can be provided. The following typical load conditions per support point are calculated:

- weight
- temperature
- static G
- emergency shutdown
- hydrostatic test

The codes ASME B31.1, ASME B31.3 and BS806 are observed for the calculations. The relevant code is to be defined on ordering according to version and year.

Constant & Variable	Type	Prior to Cold Pull	Pre Hydro Test	Post Hydro Test
HB3-MS-1-C-1	Constant	Install and unblock	Block	Unblock
HB3-MS-1-C-2	Constant	Install and unblock	Block	Unblock
HB3-MS-1-C-3E/3W	Constant	Install and unblock	Block	Unblock
HB3-MS-1-C-4	Constant	Install and unblock	Block	Unblock
HB3-MS-1-C-5	Constant	Do not install (see note 2)	Install & Block	Unblock
HB3-MS-1-C-7	Constant	Do not install (see note 2)	Install & Block	Unblock
HB3-MS-1-C-8	Variable	Install but leave blocked	Block	Unblock
HB3-MS-2-C-1	Constant	Install and unblock	Block	Unblock
HB3-MS-2-C-2	Constant	Install and unblock	Block	Unblock
HB3-MS-2-C-3N/3S	Constant	Install and unblock	Block	Unblock
HB3-MS-2-C-5	Constant	Do not install (see note 2)	Install & Block	Unblock
HB3-MS-2-C-6	Constant	Do not install (see note 2)	Install & Block	Unblock
HB3-MS-2-C-7	Variable	Install but leave blocked	Block	Unblock
HB3-MS-1-SH-1	Variable	Install but leave blocked	Block	Unblock
HB3-MS-1-SH-2	Variable	Install but leave blocked	Block	Unblock
HB3-MS-2-SH-3/4	Variable	Install but leave blocked	Block	Unblock

Solid & Dynamic	Type	Prior to Cold Pull	Pre Hydro Test	Post Hydro Test
HB3-MS-1-R-1	Solid	Install (see note 3)	Install	Install
HB3-MS-1-SW-4	Snubber	Do not install	Install	Install
HB3-MS-1-RS-4	Rigid Strut	Install	Install	Install
HB3-MS-1-SW-7	Snubber	Do not install	Install	Install
HB3-MS-1-RS-5	Rigid Strut	Do not install	Install	Install
HB3-MS-2-R-1	Solid	Install (see note 3)	Install	Install
HB3-MS-2-SW-4	Snubber	Do not install	Install	Install
HB3-MS-2-RS-4	Rigid Strut	Install	Install	Install
HB3-MS-2-SW-1	Snubber	Do not install	Install	Install
HB3-MS-2-SW-2	Snubber	Do not install	Install	Install
HB3-MS-2-SW-7	Snubber	Do not install	Install	Install
HB3-MS-2-RS-5	Rigid Strut	Do not install	Install	Install
HB3-MS-2-SW-8	Snubber	Do not install	Install	Install

Additional Notes

- Before start up check pipe falls are O.K. before and after expected thermal expansion.
- Prior to Cold Pull the boiler end of the CP gap will require a temporary support in lieu of MS-2-C-566 and MS-1-C-667
- Cold Pull is achieved by holding turbine end of the CP gap and lowering the solid supports MS-2-R1 and MS-1-R1 and also lowering any temporary support on boiler side
- Ensure Snubbers have enough travel to allow free thermal movement after installation
- Springs should only be unblocked after installation of insulation and removal of hydro water
- Position of rigid strut and snubber clamps should be checked against support drawings

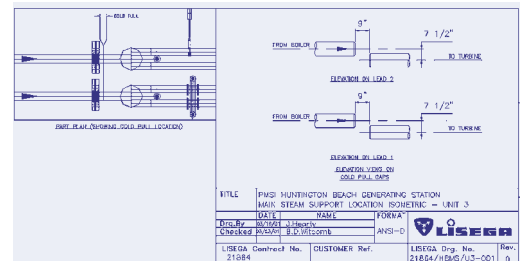

ON SITE SERVICE

The operational safety of pipe systems and therefore the availability and long life of the plants is dependent to a large degree on the condition and functional capacity of the supports employed.

To avoid costly damage and operational breakdown the regular inspection of thermal movement in piping systems and the condition of supports - especially in older installations - is urgently advised.

9.9 Plant service

Additional stress and strain caused by low-quality pipe supports during pipe system operation can lead to long-term damage that considerably increases the risk of malfunction and breakdown when the plant is in operation.

Faults frequently occurring in pipe supports are:

- poor support designs
- faulty installation
- incorrect load settings
- inappropriate instructions
- deficient quality of support components

A particular problem often arises in older installations when variable spring and constant hangers are installed with springs that are not pre-relaxed (see page 1.16 in this respect). Through the increasing relaxation over a period of time a growing loss of ultimate load gradually occurs. Load deviations resulting from this can lead to impermissible additional stress in sensitive areas, e.g. at connection points. Timely inspection in the plant can contribute to the prompt identification and elimination of critical stresses.



Checking piping movements

For this special service LISEGA offers the resources of an internationally leading manufacturer maintaining a team of qualified and experienced specialists at all group locations.

This team inspects the thermal movement in the piping system and checks the support systems. They produce comprehensive reports and provide the appropriate recommendations for a solution. Special software is implemented for the presentation and documentation of findings.

The service team is expressly trained for the execution of specific services in the field of pipe supports and works strictly according to the guidelines laid down by quality management and the relevant safety standards.

Specimen of a hanger check list from a plant



List of inspected constant and spring hangers										Rec.cold set: 11.12.1999		Close to the turbine		Name: E.Gerken		H Insp.of install.situation																			
Plant: Ayoun Moussa Power Plant Unit 1										Rec.cold set:		others were made by Skoda				I Contr.of the upper con.																			
System: Main Steam										Rec.in operat.:		19.11.2000		Name: A.Thämlitz, E.Gerken		J Insp.of the thread-depth																			
Elevation means: The connection point to the pipe																K Pos.Indent. (name plate)																			
										Date in cold condition		Date in operational condition				L Visual Inspect.																			
										Cold pos.		Travel reserve		Operat.pos.		Travel reserve		M Insp.of gen.condition																	
No.	Elev. (m)	Support No.	Type	Serial No.	Calibr. Lad (KN)	Theor.trav. up (mm)	Theor.trav. down (mm)	Load scale (KN)	required white St. (mm)	actual (mm)	Com-pare (mm)	E1 up (mm)	E1.1 down (mm)	E1.2 down (mm)	E1.3 down (mm)	Trav. Poss.	required red St. (mm)	actual (mm)	Com-pare (mm)	F1 up (mm)	F1.1 down (mm)	F1.2 down (mm)	F1.3 down (mm)	Trav. Poss.	Requ. Travel (mm)	Actual Travel (mm)	H	I	J	K	L	M			
1 R	10,50	1AB-H-01- 012	216418	9775794 /	20,75	0	58	125	125	0	125	275	217	183	180	3	180	220	122	-58	-55														
1 L	10,50	1AB-H-01- 012	216418	9775794 /	23,00	0	58	145	145	0	145	255	197	203	205	-2	205	195	147	-58	-60														
2 R	10,50	1AB-H-01- 073	216418	9870351 /	16,00	0	58	80	80	0	80	320	262	138	135	3	135	265	77	-58	-55														
2 L	10,50	1AB-H-01- 073	216418	9870351 /	19,55	0	58	120	120	0	120	280	222	178	170	8	170	230	112	-58	-50														
3 R	10,50	1AB-H-01- 074	216418	9870351 /	23,06	0	58	165	165	0	165	235	177	223	190	33	190	210	132	-58	-25														
3 L	10,50	1AB-H-01- 074	216418	9870351 /	15,15	0	58	70	70	0	70	330	272	128	95	33	95	305	37	-58	-25														
4 R	10,50	1AB-H-01- 013	216418	9775794 /	24,60	0	58	160	160	0	160	240	182	218	225	-7	225	175	167	-58	-65														
4 L	10,50	1AB-H-01- 013	216418	9775794 /	25,95	0	58	180	180	0	180	240	162	238	225	13	225	175	167	-58	-45														
						0	201		15	15							216																		

The range of services includes the following performance sectors:

9.9.1 Inspection of pipe supports

- inspection of general condition of pipe supports
- load and travel checks for spring supports
- function testing of constant and variable spring hangers with mobile test equipment at the plant or on stationary test benches at a LISEGA facility. The findings are automatically recorded.

9.9.2 Inspection of piping movements

- inspection of the general condition of the piping itself and if necessary the geometrical positioning.
- checking of piping system for unrestricted freedom of movement in all three planes.
- determination of vertical movements at all support points, and in all three planes at piping connections and selected points.

9.9.3 Design of supports at the plant

- design and planning of pipe supports in the event of renewal and modification in older installations
- measurement work at the plant
- solving problems posed by restricted space
- design of pipe supports with LICAD, EASYTEEL and AutoCAD
- preparation of parts lists and material data

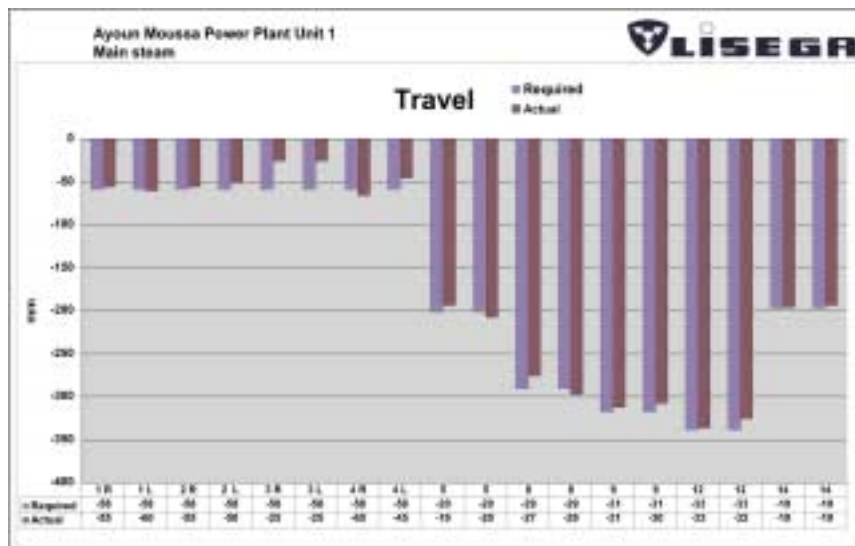

9.9.4 Supervision of construction, installation and commissioning

- material reception and control
- organization and administration of warehouse stocks
- pre-assembly and arrangement of complete support configurations
- installation of supports at the designated points
- supervision of installation of piping systems into the supports prepared
- inspection of the system as to correct installation according to drawings and installation and operation instructions
- deblocking and commissioning the supports according to an agreed procedure
- load and travel checks according to requirements after commissioning
- inspection for freedom of movement of the pipe system in all three planes
- later regulation of the hangers in the event of any load differences detected

Graphic display of piping system movements

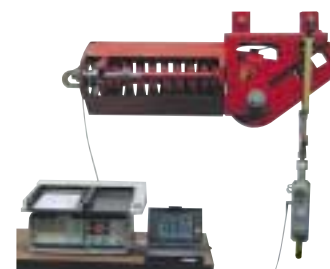

Testing constant hangers on site with a mobile test bench.

Discussion on findings and observations in pipe systems inspected.



Check on correct installation

9.9.5 Maintenance, inspection and checking of shock absorbers

- visual inspection to identify signs of possible functional disorders
- function testing on mobile benches at the plant or on corresponding testing facilities at the works
- installation and dismantling, with subsequent transportation to the testing facilities
- the function testing with corresponding electronic documentation of findings can be carried out for all makes

9.9.6 Servicing of shock absorbers after lengthy operational use or after overloading

- dismantling of shock absorbers and documentation of external state and environmental conditions



Supervision of support installation

- function testing after dismantling and documentation of results
- dismantling of shock absorbers and inspection of individual components for wear or damage
- exchange of all seals and hydraulic fluid as well as other components with noticeable wear
- final function testing in line with test program and according to relevant specifications
- reinstallation at the plant
- preparation of complete final documentation



The LISEGA on-site service spectrum applies especially to the use of pipe supports and their effect on pipe systems. On corresponding utilization, the LISEGA service package provides a valuable contribution to the functional safety and long life of complex pipe systems.

Testing PSA shock absorbers at the plant with a mobile LISEGA test bench.